

COMTEC / CAPITOL PARTITIONS INDUSTRIES
 600 WINFIELD AVE. SCRANTON, PA. 18507 1(800)-445-5148

STANDARD ELEVATIONS
 (Drawings are not to scale)
 *Floor Mounted Overhead Braced
 *Integral Hinge
 *Continuous Plastic Brackets

Note: "Job-Specific Specifications" for all orders are located on the top of the shop drawing layouts.

* HEATSINC NOTE: Heatsinc is to be placed on the bottom of the panels & doors. (If specified)

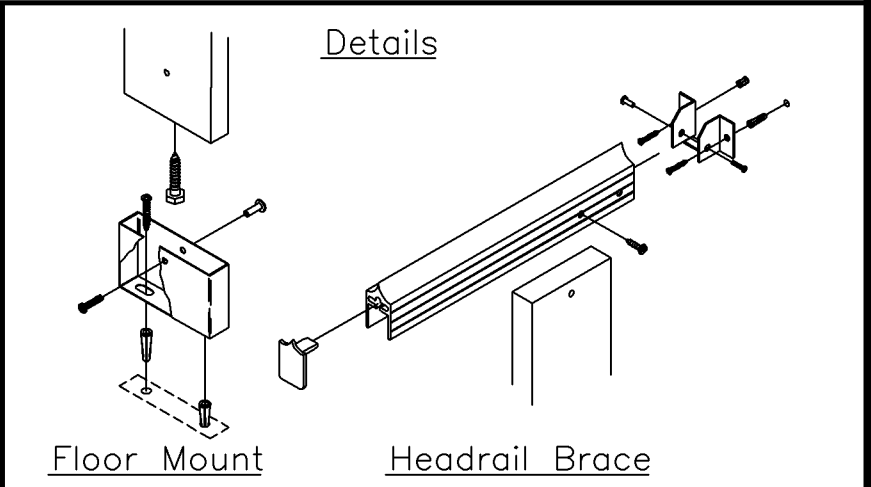

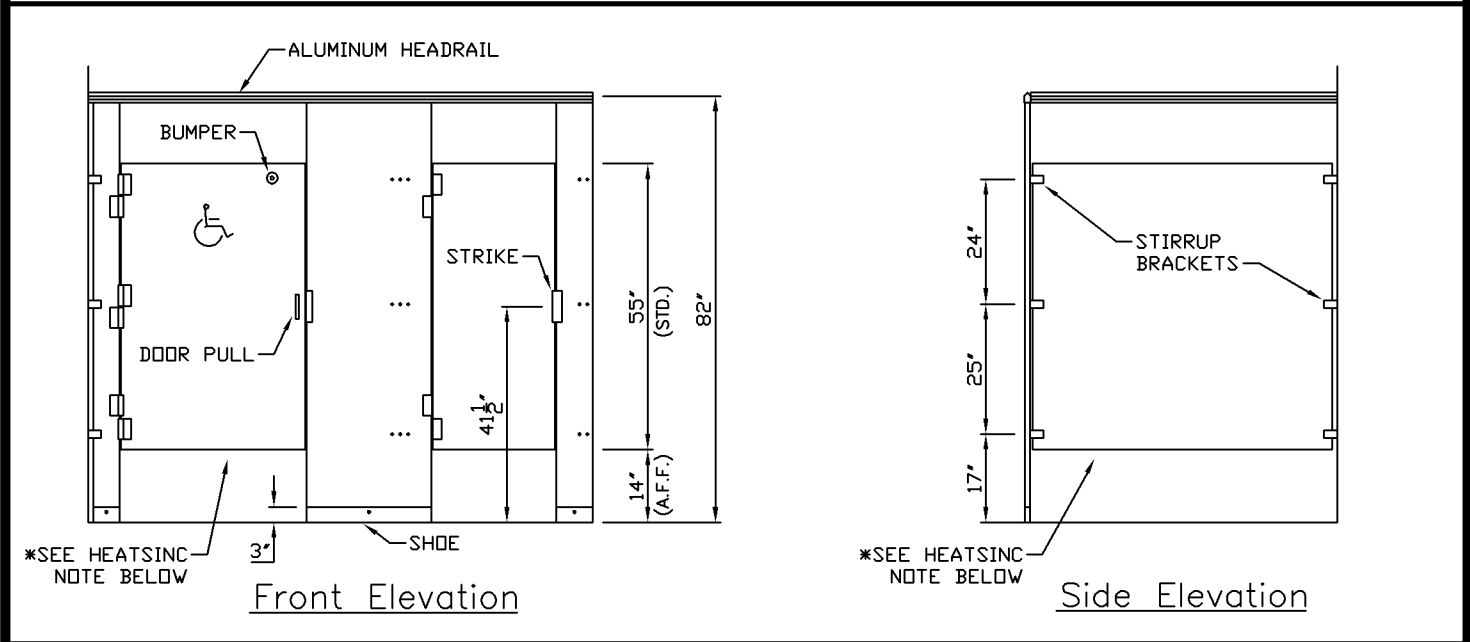
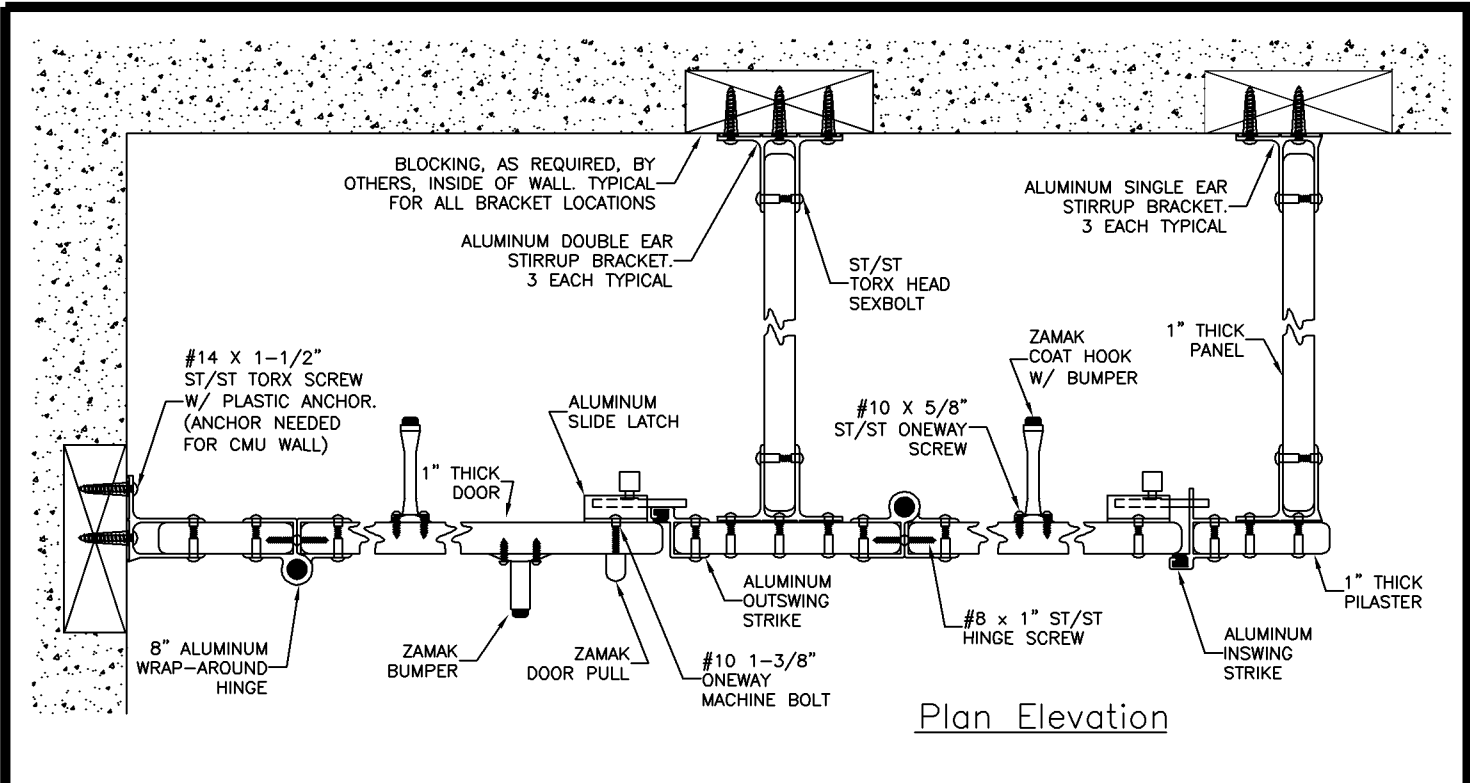

COMTEC / CAPITOL PARTITIONS INDUSTRIES
 600 WINFIELD AVE. SCRANTON, PA. 18507 1(800)-445-5148

STANDARD ELEVATIONS
 (Drawings are not to scale)
 *Floor Mounted Overhead Braced
 *8" Aluminum Wrap-Around Hinge
 *Stirrup Brackets

Note: "Job-Specific Specifications" for all orders are located on the top of the shop drawing layouts.

* HEATSINC NOTE: Heatsinc is to be placed on the bottom of the panels & doors. (If specified)

