



U280

Folded Towel Dispenser

Revision 01/17

JOB #:

ITEM #:

QUANTITY:

MOUNTING	HANDING	TYPE	SIZE	OTHER

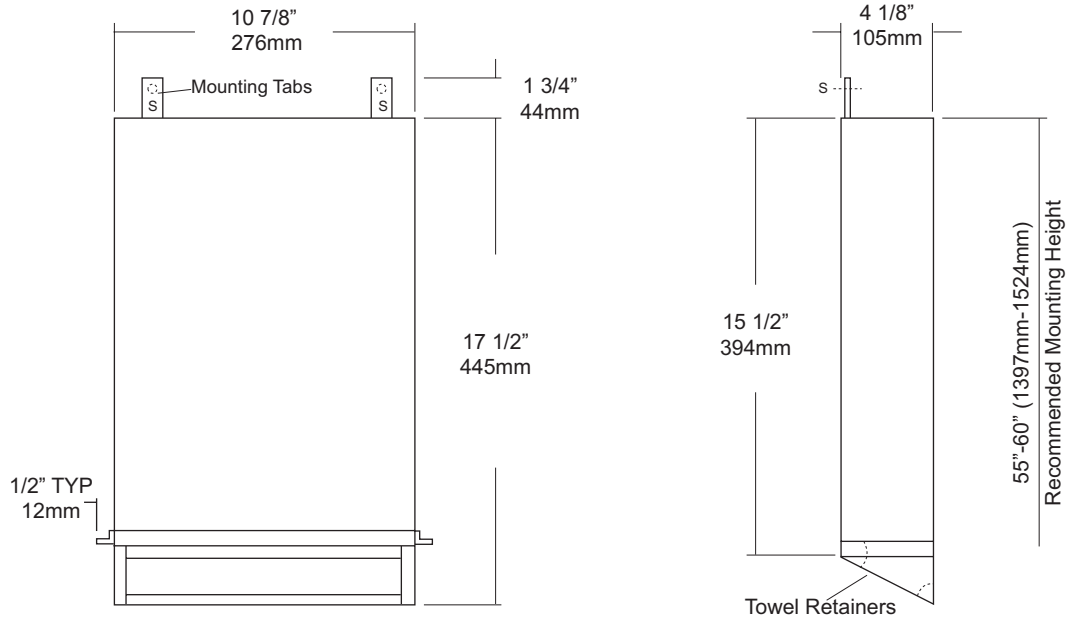

SPECIFICATIONS

Cabinet: Fabricated of #22 ga. stainless steel formed for rigidity with multiple welds to cabinet body. Spring loaded paper towel retainers are permanently attached to cabinet body by means of a full length piano hinge. Dispenser has hemmed edges to prevent towel tearing and injury. All exposed surfaces have a #4 satin finish.

Overall Size: 10 7/8"W x 17 1/2"H x 4 1/8"D
(276mm x 445mm x 105mm)

Wall Opening: 11 1/8"W x 17 5/8"H x 4 1/8"D
(283mm x 448mm x 105mm)

Towel Capacity: 600 c-fold or 800 multifold

INSTALLATION

Provide a rough wall opening 11 1/8"W x 17 5/8"H x 4 1/8"D with a minimum recessed depth of 4 1/8". Insert unit into wall opening and secure unit at points indicated on drawing by letter "S". Coordinate installation with architect or contractor to avoid interference with pipes, vents, etc. in wall. Fasteners are not supplied.

NOTES