

JOB #:

ITEM #:

QUANTITY:

MOUNTING	HANDING	TYPE	SIZE	OTHER
----------	---------	------	------	-------

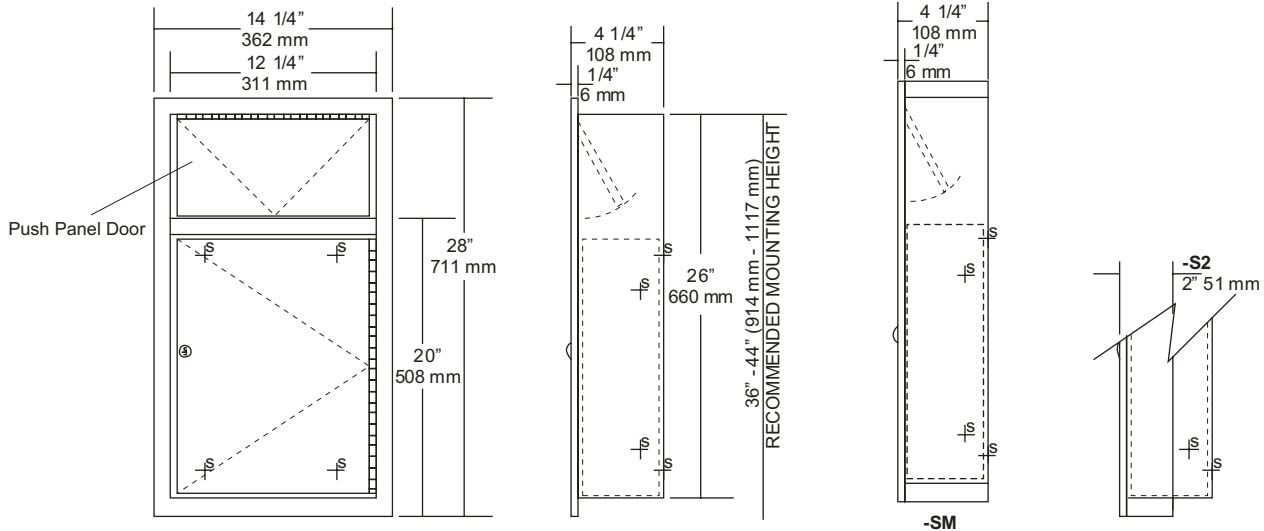

SPECIFICATIONS

Body: Fabricated of type 304 #22 gauge stainless steel with #4 satin finish on all exposed areas.

Door: Type 304 #22 gauge, one piece stainless steel secured to body by means of a full length heavy duty stainless steel piano type hinge.

Push Door: Type 304 #22 gauge stainless steel self closing door.

Flange: Type 304 #22 gauge stainless steel finished to match cabinet. One piece construction without miters or welds with 1/4" returns to wall.

Removable Waste: Heavy duty pre-plated steel with large service handle for easy servicing.

Back: Type 304 stainless steel formed for rigidity with multiple welds to cabinet.

Locks: Pin tumbler commercial quality type, keyed like all other A&J cabinets.

Collars: Type 304 #22 gauge stainless steel sized and finished to match cabinet.

Overall Size: 14 1/4"W x 28"H x 4 1/4"D
362mm x 711mm x 108mm

Wall Opening: 12 3/4"W x 26 1/2"H x 4"D
324mm x 660mm x 102mm

U442-S2: Semi-recessed with 4" (102mm) wall opening

U442-SM: Surface Mounted

Waste Capacity: 3 Gallons (.40 cu ft)

INSTALLATION

Coordinate installation with architect and contractor. Provide a wall opening 12 3/4"W x 28 1/2"H. Wall depth will vary will vary if collars are required. Open bottom door and remove waste from cabinet and insert in wall opening. Secure unit with proper fasteners per each application. Make sure unit is plumb. After unit has been secured, place waste back into cabinet and secure door.

NOTES